

Overview

- retro-reflective sensor
- 5 m
- pulsed PinPoint LED
- push-pull
- Teach-in: remote
- cable 4 pin, 2 m
- 25 ... 60 °C
- IP 68/69K & proTect+



Picture similar



Technical data

General data

Type	Retro-reflective sensor
Special type	Hygienic design
Light source	Pulsed PinPoint LED
Actual range Sb	5 m
Nominal range Sn	6 m
Polarization filter	Yes
Light indicator	LED yellow
Power on indication	LED green
Sensitivity adjustment	Teach-in: remote
Wave length	630 nm
Suppression of reciprocal influence	Yes
Alignment optical axis	< 2°
Approvals/certificates	Ecolab Adapted from EHEDG

Electrical data

Response time / release time	< 0.49 ms
Voltage supply range +Vs	10 ... 30 VDC
Current consumption max. (no load)	35 mA

Electrical data

Current consumption typ.	25 mA
Voltage drop Vd	<3 VDC
Output function	Light / dark operate
Output circuit	Push-pull
Output current	100 mA
Short circuit protection	Yes
Reverse polarity protection	Yes

Mechanical data

Width / diameter	16.5 mm
Height / length	34.6 mm
Depth	28.7 mm
Design	Rectangular
Housing material	Stainless steel 1.4404 (V4A)
Front (optics)	PMMA
Connection types	Cable 4 pin, 2 m

Ambient conditions

Operating temperature	-25 ... +60 °C
Protection class	IP 68/69K & proTect+

Remarks

- Magnetic Teach

O300H.RP-GW1B.PVCK

Retro-reflective sensors - hygiene

Article number: 11127716

Technical drawings

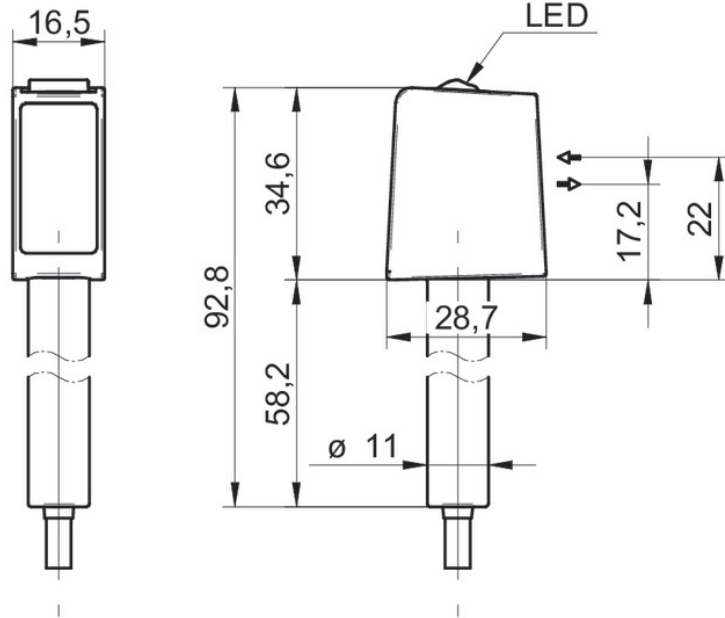

Connection diagram

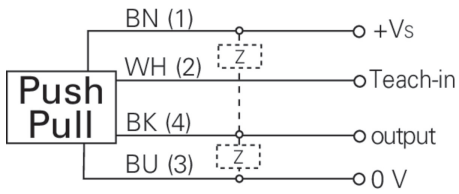

Excess gain curve

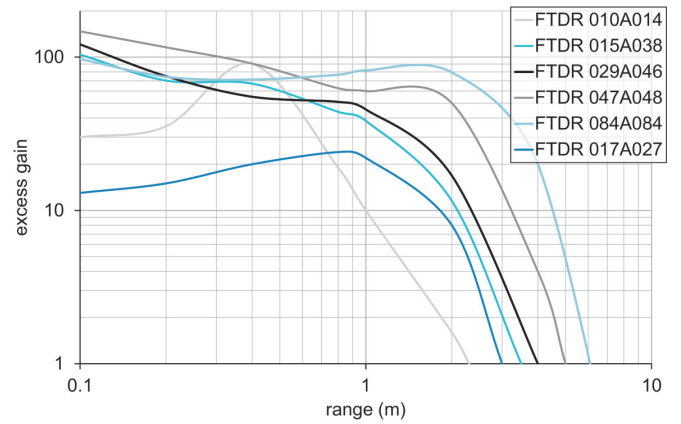

Beam characteristic (typically)

